

COMPACT VARIABLE LASER POWER ATTENUATORS – 990-0077, 990-0078

Features

- Attenuation range for transmitted beam:
 - Typical: 0.1% – 98%
 - For 257 nm and 266 nm: 1% – 96%
- Attenuation range for reflected beam
 - Typical: 2% – 99.9%
 - For 257 nm and 266 nm: 4% – 99%
- Extinction ratio: >1:1000
- Clear aperture:
 - 990-0077 – Ø17 mm
 - 990-0078 – Ø22 mm



990-0077 and 990-0078 Laser Power Attenuators

This manual variable attenuator series is designed to continuously attenuate linearly polarized laser beams. They feature precision opto-mechanics and high-LIDT optical components incorporated in a compact housing to ensure stable and reliable performance.

Attenuators are based on Brewster-type thin film polarizer fixed at 56° and a quartz half waveplate. The Polarizer's angle of incidence can be manually adjusted to get the best contrast or to manipulate the direction of the reflected s-polarized beam. The waveplate is housed in a 360° continuous rotation mount, which can be manually rotated to control the output power of the transmitted and reflected beams.

The intensity of either exit beam or their intensity ratio can be controlled over a wide dynamic range without alteration of other beam parameters. Pure p-polarization could be selected for maximum transmission, or pure s-polarization for maximum reflection. The s-polarization exit port can be blocked with a removable low-power dumper which absorbs laser power up to 5 W. External beam dumps are recommended for high-power applications.

990-0077 COMPACT VARIABLE ATTENUATORS WITH A CLEAR APERTURE OF Ø17 mm

Specifications

| | |
|-------------------------|---------|
| Clear aperture diameter | 17 mm |
| Polarization contrast | >1:1000 |

| Wavelength, nm | LIDT | Attenuation range (Tp) | Catalogue number |
|----------------|--|------------------------|-------------------------------|
| 257 | 1 J/cm ² @ 257 nm, 10 Hz, 10 ns | 1% – 96% | 990-0077-257 |
| 266 | 1 J/cm ² @ 257 nm, 10 Hz, 10 ns | 1% – 96% | 990-0077-266 |
| 343 | 3 J/cm ² @ 343 nm, 10 Hz, 10 ns | 0.1% – 98% | 990-0077-343 |
| 355 | 3 J/cm ² @ 355 nm, 10 Hz, 10 ns | 0.1% – 98% | 990-0077-355 |
| 515 | 5 J/cm ² @ 515 nm, 10 Hz, 10 ns | 0.1% – 98% | 990-0077-515 |
| 532 | 5 J/cm ² @ 532 nm, 10 Hz, 10 ns | 0.1% – 98% | 990-0077-532 |
| 1030 | 10 J/cm ² @ 1030 nm, 10 Hz, 10 ns | 0.1% – 98% | 990-0077-1030 |
| 1064 | 10 J/cm ² @ 1064 nm, 10 Hz, 10 ns | 0.1% – 98% | 990-0077-1064 |

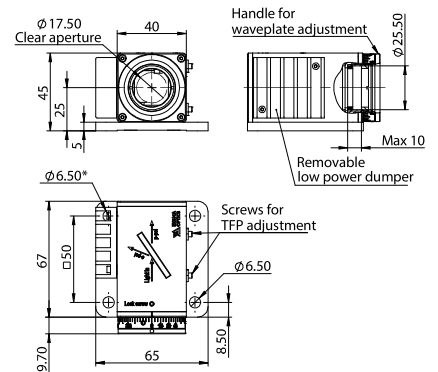

990-0078 COMPACT VARIABLE ATTENUATORS WITH A CLEAR APERTURE OF Ø22 mm

Specifications

| | |
|-------------------------|---------|
| Clear aperture diameter | 22 mm |
| Polarization contrast | >1:1000 |

| Wavelength, nm | LIDT | Attenuation range (Tp) | Catalogue number |
|----------------|--|------------------------|-------------------------------|
| 257 | 1 J/cm ² @ 257 nm, 10 Hz, 10 ns | 1% – 96% | 990-0078-257 |
| 266 | 1 J/cm ² @ 257 nm, 10 Hz, 10 ns | 1% – 96% | 990-0078-266 |
| 343 | 3 J/cm ² @ 343 nm, 10 Hz, 10 ns | 0.1% – 98% | 990-0078-343 |
| 355 | 3 J/cm ² @ 355 nm, 10 Hz, 10 ns | 0.1% – 98% | 990-0078-355 |
| 515 | 5 J/cm ² @ 515 nm, 10 Hz, 10 ns | 0.1% – 98% | 990-0078-515 |
| 532 | 5 J/cm ² @ 532 nm, 10 Hz, 10 ns | 0.1% – 98% | 990-0078-532 |
| 1030 | 10 J/cm ² @ 1030 nm, 10 Hz, 10 ns | 0.1% – 98% | 990-0078-1030 |
| 1064 | 10 J/cm ² @ 1064 nm, 10 Hz, 10 ns | 0.1% – 98% | 990-0078-1064 |

